

Solar Street Light – 20W

Model: HL-1504

Harbour Lighting's solar street light is a simple solution to provide lighting to an area with no operational costs by using power free from the grid. The solar area lights range is fully flexible for most lighting needs.

Product Features

- One operation mode: Dimmed Brightness (15%) until motion activated (100%)
- 3 Installation options
- Automatic night time operation
- Remote control
- Waterproof (IP65)
- High Strength fire proof anti UV PC



INSTALLATION

(1) Pole Installation

(2) Horizontal installation

(3) wall mounted

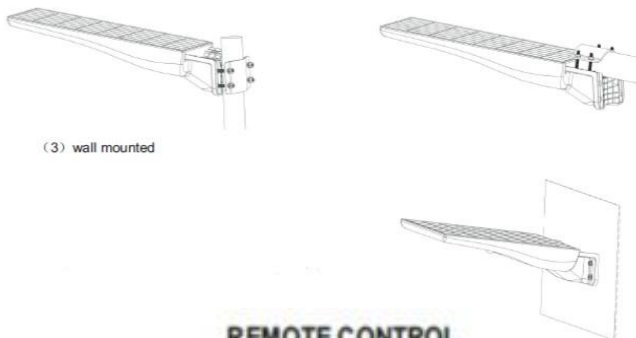

REMOTE CONTROL



SPECIFICATION

Part Number	HL-1504
Colour	5500K
Lumen (lm) – Full	2500lm
Light Source	LED
Beam Angle	120°
Power Requirement	Solar panel north facing
Power Consumption	20W
Battery Type	Lifepo4 Battery
Charging time	6-8 Hours of bright sunlight
Redundancy	~ 3 Days +
Housing	High Strength fire proof UV PC
Operation Temperature	-20°C~+60°C
Light Dimension (mm)	506 (L) x 183(H) x 80(D)
Mounting Height	3-6 Metres
PIR	Up to 12metres
Light Weight	1.8kg
Warranty	3 year

Harbour Lighting

www.harbourlighting.com.au

Email: sales@harbourlighting.com.au